

PREFORM DESIGN AT AXISYMMETRIC HOT CLOSED-DIE FORGING USING SIMPLE MOVING AVERAGE SMOOTHING TECHNIQUE

Rossen RADEV, Danail GOSPODINOV, Mariana ILIEVA, Nikolay FERDINANDOV

University of Ruse, Ruse, Bulgaria, EU, rradev@uni-ruse.bg, dgospodinov@uni-ruse.bg, mdilieva@uni-ruse.bg, nferdinandov@uni-ruse.bg

<https://doi.org/10.37904/metal.2024.4932>

Abstract

Forging is currently one of the most economical processes for the manufacture of parts for industry. Product quality and production costs are very significant factors for manufacturers today and determines their competitiveness. The design of preforms is an important aspect for improving the quality of forging parts and reducing the manufacture costs.

This paper presents a new opportunity to design preforms for closed-die hot forging using a simple moving average smoothing technique. As examples, the preform design of axisymmetric forgings is performed. Computer simulations of the forging processes in the preform and final forging stages was carried out. The results are compared and analyzed.

Keywords: Hot closed-die forging, preform design, simple moving average smoothing

1. INTRODUCTION

Nowdays, forging is still a cost-effective way to produce net-shape or near-net-shape parts. During the forging process, a metal workpiece is deformed plastically, both to achieve the desired form of the forged component and to obtain a combination of appropriate physical and mechanical properties. Selecting the proper types and sequence of operations at hot closed-die forging ensures the achievement of the above requirements, together with reducing the manufacturing costs and minimizing the enviromental impact. The role of preform stage is crucial as it directly affects the metal flow in final impression, determining the quality of the forged part and die wear.

Preform design task is strongly connected with another engineering problem - the question about necessity of preform stage. Most often in practice, engineers determine the necessity of preform steps on the base of the manufacturing experience, the expert valuation or the base of trial - error method. Such practical recommendations, regarding the decision of the necessity of preform stages and their shape are pointed in handbooks [1, 2], where they are seen as interrelated. Considering the question of the shape of the preform at hot closed-die forging many authors offer solutions as a priori accept that a preform is necessary. Decisions on the base of model material experiments are proposed in [3, 4]. In [5, 6] an approach using upper bound elemental technique are pointed out. The development of computers and the computational procedures is the reason why various preform design methods are increasingly assisted with numerical metal forming simulations. Generally, modelling and simulations of metal forming processes gives a strong push to the development of the various methods and procedures for the preform design at hot closed-die forging. Many authors using geometrically techniques, often together with sensitive analysis, for preform design, analyzing the movement of characteristic points of the contour of the forgings [7-10]. Solutions of the task of preform shapes on the base of geometrical resemblance are given in [11, 12]. Preform design methods using fuzzy logic are used in [13, 14]. The variety of design approaches is complemented by techniques using

approximations with mathematical equations [15], neural networks [16], isothermal surfaces [17], topological optimization [18].

The wide variety of methods and techniques for preform design illustrates not only the great creativity of different researchers, but also the relevance of the issue, as well as the lack of a uniform and universal decision to the task of preform shape. Solutions shown in the text above are valid for specific part shapes and dimensions, or are usable only for preform shape optimization, not actually preform design. Very often, complex computational procedures are required for their implementation, which makes them inconvenient for practice.

The aim of this article is to present an opportunity for preform design at axisymmetric hot closed-die forging on the base of simple moving average smoothing technique.

2. SIMPLE MOVING AVERAGE

A moving average (MA) is a statistical function that involves the computation of a series of averages of different subsets of values from a given set. For a certain set of data values and for a fixed subset size, the first moving average is the average of the initial fixed subset of the data values. On the next step, the next moving average is calculated after excluding the first value of the data series and including the next value in the subset. Different varieties are found – simple moving average (SMA), cumulative average, weighted moving average, etc.

The MA is most commonly used in time series for trend analysis, allowing short-term fluctuations to be smoothed out and longer-term trends to emerge. In finance, moving averages are one of the core indicators in technical analysis. From mathematically point of view, MA is an example of a low-pass filter and can be used in signal processing. Thus, the moving average smoothing the data.

Simple moving average (SMA) is the unweighted mean of the previous k datapoints and can be expressed:

$$SMA_k = \frac{1}{k} \sum_{i=n-k+1}^n p_i \quad (1)$$

where:

n – number of dataset entries

k – number of subset entries

p_1, p_2, \dots, p_n – data values

3. PREFORM DESIGN METHOD

The procedure starts with dividing of the contour of the forging on upper and bottom part, according to parting line. Coordinates of the points describing the shape of each of the two (upper and bottom) parts are collected to sets of data and represented in the form of a functions. The next step requires the application of equation (1) for each of functions. As result of previous operation, a new set of point coordinates are obtained. The newly obtained point coordinates describe the contour of the preform die impression (fig.1).

An important feature of the methodology used in this article is the selection of the quantities k and n . For the most common cases of forgings with a mass m of up to 65 kg and an overall diameter of forging $D_F = 2R_F$ up to 700 mm, appropriate values are (**Figure1**):

$$k = \frac{R_F}{10} \div \frac{R_F}{15}$$

For n , appropriate values are defined from condition for distance between two adjacent points from the shape contour (**Figure1**):

$$\Delta r = \frac{r_{min}}{2} \div r_{min}$$

where r_{min} is the smallest radius of contour of the forging part shape.

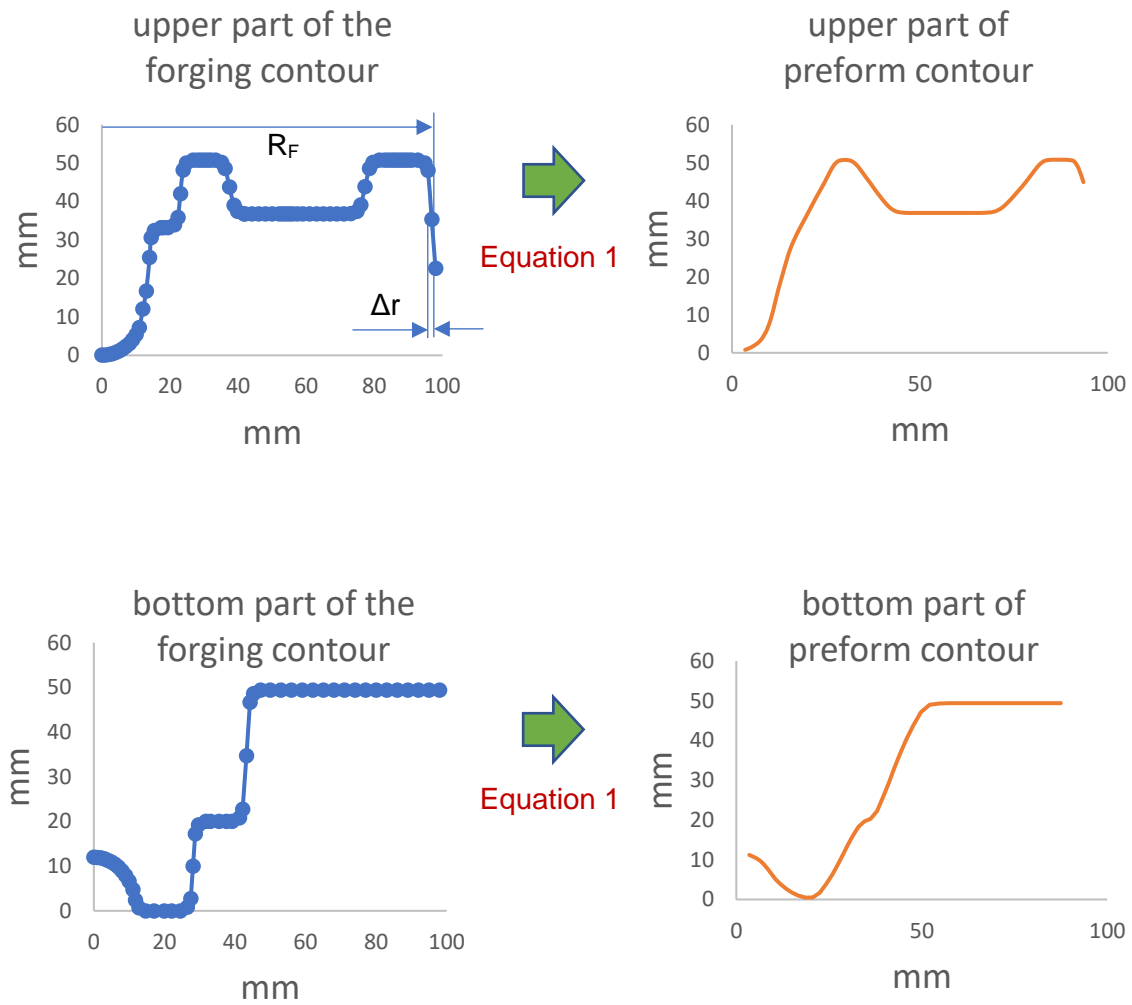

Figure 1. Contours (right half) of the upper and bottom part of forging (left) and preforming (right).

4. EXPERIMENTS

As examples in this paper, three preform shapes have been designed using the describing above simple moving average technique. The preformings are shown in **Figure 2**, together with forgings. In order to confirm the adequacy of the proposed preform design solutions, computer simulations of hot closed-die forging were carried out. The initial conditions for computer simulations has been chosen as follows: deformed material – low-carbon steel, forging equipment – mechanical press, forging temperature $T_F = 1100^\circ\text{C}$, temperature of dies – $T_D = 300^\circ\text{C}$, lubricant – emulsion of graphite and water. Forging simulations were performed by the following sequence: upsetting of billet with round cross section – preform stage – final forging stage.

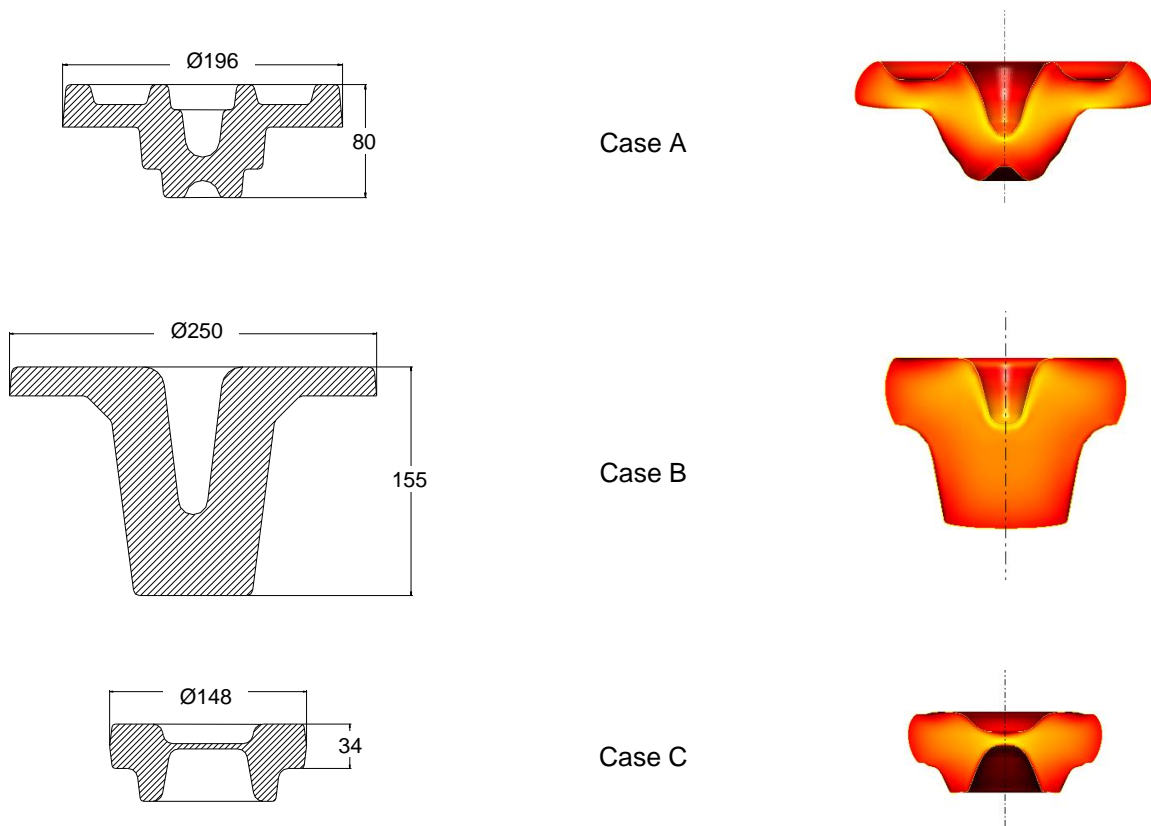

Figure 2 Forgings (left) and preformings, designed using simple moving average technique (right).

The investigated shapes cases A, B, C, have been chosen to demonstrate the proposed simple moving average technique. The parting line, dividing the forging into upper and lower parts, is made up of line segments for Case A and Case B. Case C is with straight parting line. Case B has another feature – the shape of forging is more typical for upset forging method.

5. RESULTS AND DISCUSSION

After computer metal forming simulation, defect free forging in finishing impression was obtained for all three cases of designed preforms. Die filling was adequate, without cracks and laps. For example, the metal flow lines for Case A, together with temperature distribution are shown on **Figure 3**. Effective strain distribution for Case B is shown on **Figure 4**. The distribution is relatively uniform with higher values observed around those parts of the die forming the central hole. This is a well-known feature when forming axisymmetric forgings. Not coincidentally, these are also the most mechanically stressed and fastest wearing areas of the metal forming dies. Effective strain distribution for Case A and Case B is relatively uniform, also.

Comparing works done for three different forgings, shown in **Table 1**, it is obvious that much of the necessary forming work is done in the preform impression for Case A and Case C. This, to a significant extent, unloads the final impression die and is a prerequisite for reducing its wear, as well as for lower manufacturing expenditures. For Case B, the work done in final forming stage is considerably bigger relative to preform impression die. The maximum values of the required forces during metal forming are shown in **Table 2**.

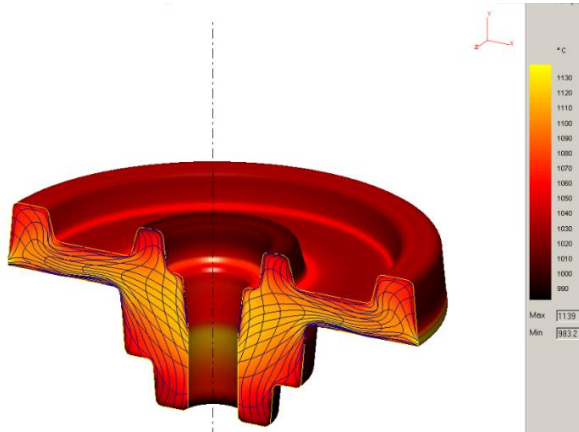

Figure 3 Metal flow lines and temperature distribution for Case A.

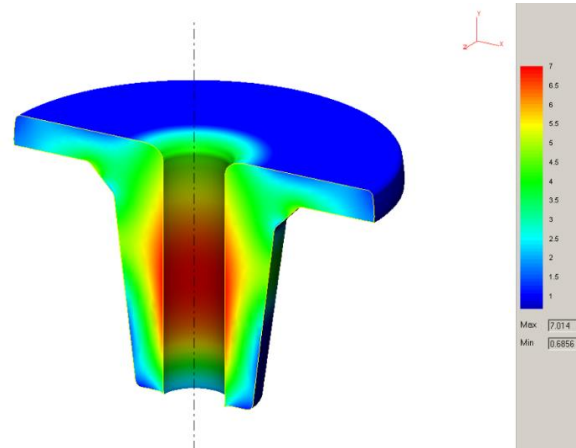

Figure 4 Effective strain distribution for Case B

Table 1 Works done for the three different cases of forging processes.

Work done [kJ]	Case A	Case B	Case C
In preform impression	61.8	98.8	49.9
In final impression	48.7	155.9	37.0

Table 2 Maximum values of the required forces during metal forming.

Force [MN]	Case A	Case B	Case C
In preform impression	3.01	2.16	1.23
In final impression	15.3	26.30	9.50

6. CONCLUSION

The results obtained applying the method of preform design for hot closed-die forging based on simple moving average allow to conclude:

- (i) it is suitable method for preform design for hot closed-die forging. This manner ensures adequate die filling and relatively uniform distribution of effective strains. This defines decreasing of die wear and manufacturing expenditure.
- (ii) the simple moving average technique allows quickly and easy formalizing and computer automation of the task of preform design at hot closed-die.

ACKNOWLEDGEMENTS

This study is financed under project No. 2024 - MTF- 01 "Development and research of digital technological methods".

REFERENCES

- [1] SEMIATIN, S. L. (Editor) *ASM Handbook, Volume 14A: Metalworking: Bulk Forming*, Materials Park: ASM International, 2005.
- [2] SEMENOV E.I. (Editor) *Kovka i shtampovka, T.2. Goryachaya obemna shtampovka*, Moskva: Mashinostroenie, 2010
- [3] BISWAS, S. K., KNIGHT, W. A. Preform design for closed die forgings: experimental basis for computer aided design. *International Journal of Machine Tools & Manufacture*. 1975, Vol. 15, pp. 179-193.
- [4] TOMOV, B., WANHEIM, T. Preform design based on model material experiments, In: *Proceedings of the International Conference on Advanced Mechanical Engineering & Technology (AMTECH), section 2*. Rouse: University of Rouse, 1993, pp. 147-156.
- [5] ALMOHAILEB, M., GUNASEKERA, JS. MEHTA, B.V., OYEKANMI, B. Modified Upper Bound Elemental Technique (MUBET) for Preform Design in Closed Die Forging. *AIP Conference Proceedings*. 2004, Vol. 712, pp. 2062–2067
- [6] ALMOHAILEB, M., GUNASEKERA, JS. Backward Simulations using Modified Upper Bound Elemental Technique (MUBET) for Preform Design in Forging Process. [online]. 2008. [viewed: 2023-04-20]. Available from: https://www.forging.org/forging/system/files/field_document/FIERF_Mazyad_04_0.pdf
- [7] ZHAO, G., WRIGHT, E., GRANDHI, R.V. Computer aided preform design in forging using the inverse die contact tracing method. *International Journal of Machine Tools & Manufacture*. 1996, vol. 36, pp. 755-769.
- [8] SUKJANTHA, V., AUE-U-LAN, Y. Determination of Optimal Preform Part for Hot Forging Process of the Manufacture Axle Shaft by Finite Element Method. *Applied Science and Engineering Progress*. 2013, Vol 6, No 1, pp. 35-42
- [9] SILANI, M., ZIAEI-RA, S. Optimum Preform Design in Close Die Hot Forging. *Steel Research International*. 2012, pp. 191-194
- [10] MIRSAEIDI, M., BIGLARI, F., NIKBIN, K., GOUDARZI, E.M., BAGHERZADEH, S. Optimum forging preform shape design by interpolation of boundary nodes. In: *Proceedings of the world congress on engineering WCE*. London: IAENG, 2009. Vol.2.
- [11] YANG, C., NGAILE, G. Preform design for forging and extrusion processes based on geometrical resemblance. *Proceedings of the Institution of Mechanical Engineers, Part B: J. Engineering Manufacture*. 2010, Vol. 224, No 9, pp. 1409–1423.
- [12] MANSOURI, H., MOHAJERANI, A. N. Cross dies forging: A new method to reduce forging force & price up to 80% thanks to FEM method. In: *MATEC Web of Conferences*. 2016, Volume 80, 09001. Available from: <https://doi.org/10.1051/mateconf/20168009001>
- [13] BIGLARI, F.R., O'DOWD, N.P., FENNER, R.T. Optimum design of forging dies using fuzzy logic in conjunction with the backward deformation method. *International Journal of Machine Tools & Manufacture*. 1998, Vol. 38, pp. 981-1000.
- [14] HEDICKE-CLAUS, Y., KRIWALL, M., STONIS, M., BEHRENS, B-A. Automated design of multi-stage forging sequences for die forging. *Production Engineering*. 2023. Available from: <https://doi.org/10.1007/s11740-023-01190-x>
- [15] RADEV, R.H.; TOMOV, B.I. Preform design in hot die forging. In: *Proceedings of the 11th International Scientific Conference on Achievements in Mechanical and Materials Engineering*. Gliwice-Zakopane: Silesian University of Technology, Institute of Engineering Materials and Biomaterials Poland, 2002, pp. 451–454.
- [16] LEE, S., QUAGLIATO, L., PARK, D., KWON, I., SUN, J., KIM, N. A New Approach to Preform Design in Metal Forging Processes Based on the Convolution Neural Network. *Applied Sciences*. 2021, Vol. 11, Issue 17, 7948. Available from: <https://doi.org/10.3390/app11177948>
- [17] BIBA, N., VLASOV, A., KRIVENKO, D., DUZHEV, A., STEBUNOV, S. Closed Die Forging Preform Shape Design Using Isothermal Surfaces Method. *Procedia Manufacturing*. 2020, Vol. 47, pp. 268-273.
- [18] SHAO, Y., LU, B., OU, H., REN, F., CHEN, J. Evolutionary forging preform design optimization using strain-based criterion, *The International Journal of Advanced Manufacturing Technology*. 2014, Vol. 71, pp. 69–80.